



Installation, Operating and Servicing Instructions

Lynx 400 Electric Convection Oven LCO

Please make a note of your product details for
future use:

Date Purchased: _____

Model Number: _____

Serial Number: _____

Dealer: _____

The LYNX 400 logo features the word 'LYNX' in a bold, blue, sans-serif font, followed by '400' in a larger, bold, blue, sans-serif font. The '4' and '0's are significantly larger than the '0's in 'LYNX'.

CONTENTS

Important Information	2
Warnings and Precautions	3
Technical Data	3
Checklist of Enclosures	3
Installation and Commissioning	3-4
Operating Instructions	5
Cleaning	6
Servicing, Maintenance and Component Replacement	6
Fault Finding	6
Spare Parts List	6
Service Information and Guarantee	7

IMPORTANT INFORMATION



Read these instructions carefully before using this product, paying particular attention to all sections that carry warning symbols, caution symbols and notices. Ensure that these are understood at all times.



WARNING!

This symbol is used whenever there is a risk of personal injury.



CAUTION!

This symbol is used whenever there is a risk of damaging your Lincat product.

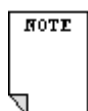

NOTE:

This symbol is used to provide additional information, hints and tips.

KEEP THIS MANUAL FOR FUTURE REFERENCE

WARNINGS AND PRECAUTIONS



This appliance must be installed, commissioned and serviced by a qualified person in accordance with national and local regulations in force in the country of installation.

If the supply cord is damaged, it must be replaced by the manufacturer, its service agent or similarly qualified person.

Ensure that the plug/socket is accessible at all times.

Strip plastic coating and clean the appliance before use.

During operation parts may become hot - avoid accidental contact.

Disconnect this appliance before servicing, maintenance or cleaning.

TECHNICAL DATA

Model	Height (mm)	Width (mm)	Depth (mm)	Weight (kg)
LCO	371	555	488	25.5

CHECK LIST OF ENCLOSURES

Warranty card

Instructions manual

2 Wire shelves

INSTALLATION AND COMMISSIONING

This appliance must be earthed.



An equipotential bonding terminal is provided to allow cross bonding with other equipment.

If replacing the plug connect the terminals as follows:

Green and Yellow wire Earth E

Blue wire Neutral N

Brown wire Live L

Supply cords shall be oil resistant, sheathed flexible cable not lighter than ordinary polychloroprene or equivalent elastomer sheathed cord (code 60245 IEC 57)

Install this appliance on a level surface ensuring all vents are unobstructed. Install this appliance on a level surface ensuring all vents are unobstructed. Any partitions, walls or furniture must be of non-combustible material. Minimum distances A 100mm B 1000mm – see Fig 1.

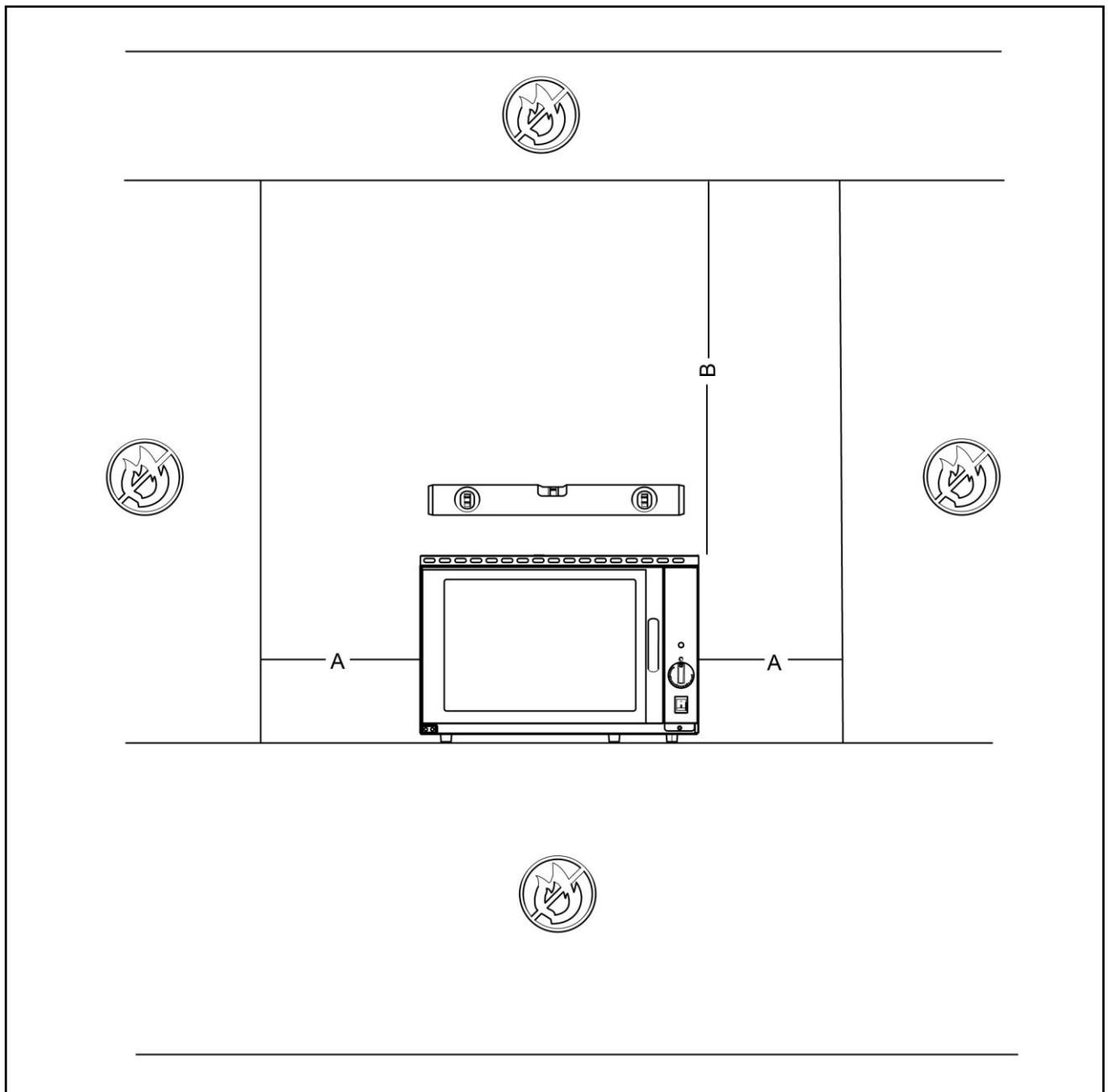

Fig 1

Power Ratings

Model	kW	Amps
LCO	2.5	10.9

OPERATING INSTRUCTIONS

Only qualified or trained personnel should use this appliance.

Connect the appliance to an electricity supply and switch on – the switch and interior light illuminate.

Turn the control knob to the desired setting – the amber neon illuminates and extinguishes when temperature is reached.

The amber neon will periodically illuminate as the element cycles.

This appliance is fitted with a safety thermostat, which will cut power to the appliance under fault conditions. If the switch illuminates but the appliance does not heat up, the safety thermostat may need re-setting. Push the red button on the rear panel (Fig 2 – A). This re-set cannot be activated until the appliance is cool.

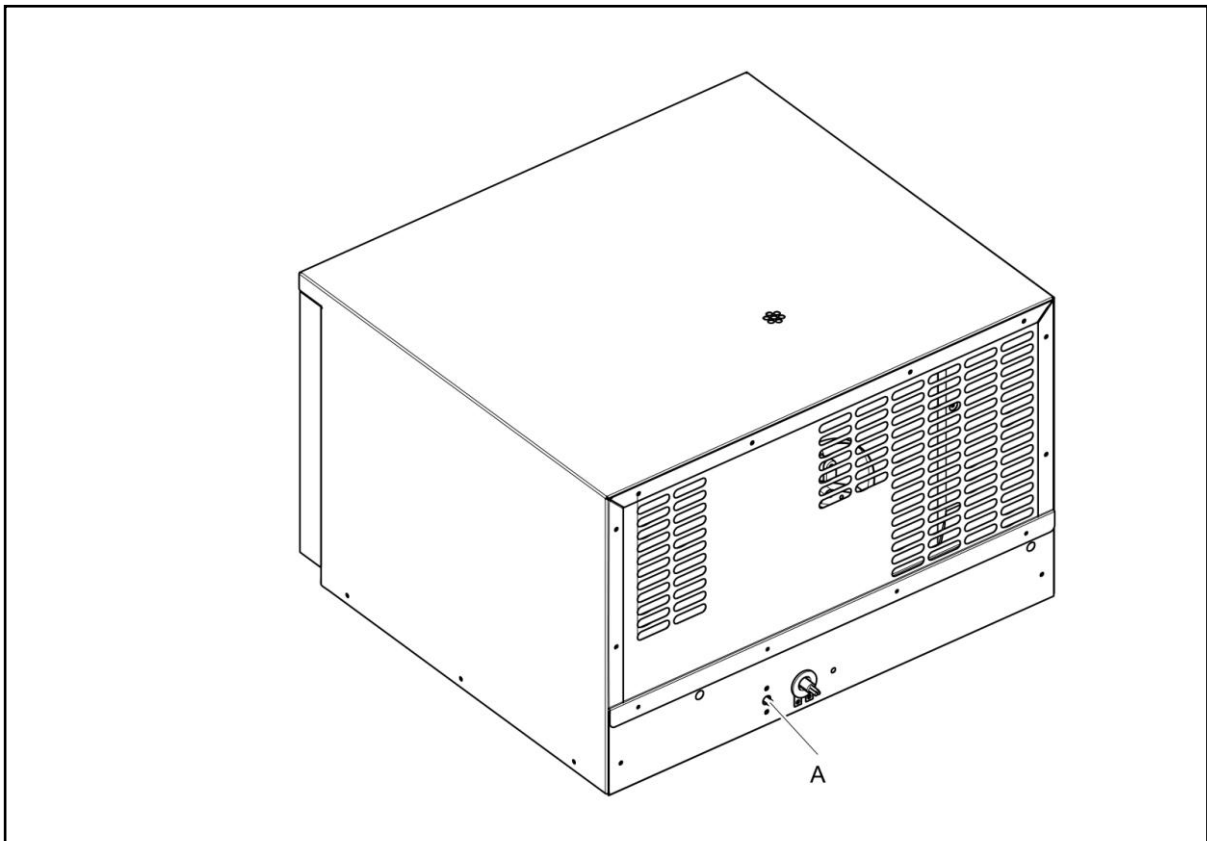

Fig 2

CLEANING



Do not use a water jet or steam cleaner, and do not immerse this appliance.

Clean all panels with warm water and mild detergent, do not use abrasive materials. Dry with a soft cloth.

SERVICING, MAINTENANCE AND COMPONENT REPLACEMENT

Door inner glass: Remove 2 screws and metal cover. Push glass sideways to remove. To replace the glass, reverse the procedure.

Light bulb: Remove the glass cover by hand. Unscrew bulb. To replace the bulb, reverse the procedure.

Door seals: Take the hook at the ends of the seal out of each hole and use the hooks to clip the new seal into place.

All other servicing, maintenance and component replacement on this appliance should be carried out by one of our recommended service engineers.

FAULT FINDING

Please refer to the Service Help Desk number on the final page of this manual.

SPARE PARTS LIST

Part Number	Description
EL232	Element
FA106	Fan
GL502	Door glass
KN245	Control knob
LA14	Lamp
NE42	Amber neon
PL202	Mains cable
SE35	Door seal – top
SE36	Door seal – side
SH104	Shelf
SW69	Switch
TH46	Control thermostat
TH61	Safety thermostat

SERVICE INFORMATION

For help with the installation, maintenance and use of your **Lincat** equipment, please contact our service department:

☎ UK: 01522 875520

For non-UK customers, please contact your local Lincat dealer

All service work, other than routine cleaning should be carried out by one of our authorised service agents. We cannot accept responsibility for work carried out by other persons.

To ensure your service enquiry is handled as efficiently as possible, please tell us:

- Brief details of the problem
 - Product code
 - Type number
 - Serial number
- } All available on serial plate

Lincat reserve the right to carry out any work under warranty, given reasonable access to the appliance, during normal working hours, Monday to Friday, 08:30 to 17:00.

GUARANTEE

This unit carries a comprehensive UK mainland 2 year warranty. The guarantee is in addition to, and does not diminish your statutory or legal rights.

The guarantee does not cover:

- Accidental damage, misuse or use not in accordance with the manufacturer's instructions
- Consumable items (such as filters, glass, bulbs, slot toaster elements and door seals.)
- Damage due to incorrect installation, modification, unauthorised service work or damage due to scale, food debris build-up, etc.

The manufacturer disclaims any liability for incidental, or consequential damages. Attendance is based on reasonable access to the appliance to allow the authorised technician to carry out the warranty work.

Service calls to equipment under warranty will be carried out in accordance with the conditions of sale. Unless otherwise specified, a maximum of 15 minutes of administrative time, not spent directly carrying out servicing work, is provided for within the warranty. Any requirement for staff attending the call to spend greater time than 15 minutes due to administrative requirements, such as on health and safety risk assessments, will be chargeable at the prevailing rate.